

INTRODUÇÃO

CURSO DE DESIGN DE JÓIAS

MÓDULOS

- CRIATIVIDADE
- CONHECIMENTO DO PRODUTO E FABRICAÇÃO
- DESENHO TÉCNICO DE PEDRAS, BRINCOS, PENDENTES E ANÉIS
- PERSPECTIVA DE ALIANÇAS
- PERSPECTIVA HEXASOMÉTRICA DE ANÉIS
- PULSEIRAS ESCRAVAS E MALEÁVEIS
- COLARES DUROS E MALEÁVEIS
- COR

CRIATIVIDADE

A criatividade é um dos fatores mais importantes para o designer, é a sua forma de ver o mundo, é o seu ponto de vista sobre a vida.

Você já pensou se todos tivéssemos pensamentos iguais?

Com certeza não teriam existido artistas como Goya, Michelangelo, Da Vinci e cientistas como Eistein, entre outras importantes personalidades que marcaram épocas e revoluções na ciência.

TÉCNICAS

BRINCAR

- MÓDULOS ART DECO, ART NOUVEU, JAPONESSES, EGÍPCIOS, ISLÂMICOS, ENTRE OUTROS QUE SE ENCONTRAM NA APOSTILA.
- JOGAR COM OS MOVIMENTOS / CHUVA, VENTO, ONDAS E ETC.
- BRINCAR COM OBJETOS DO COTIDIANO / LUMINÁRIAS, CADEIRAS, MESAS E ETC.

MÓDULOS

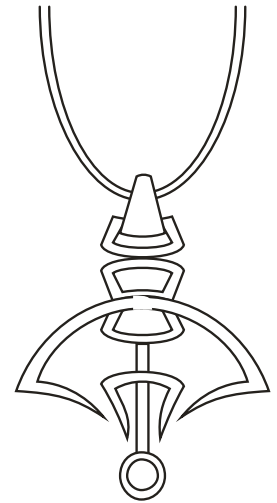
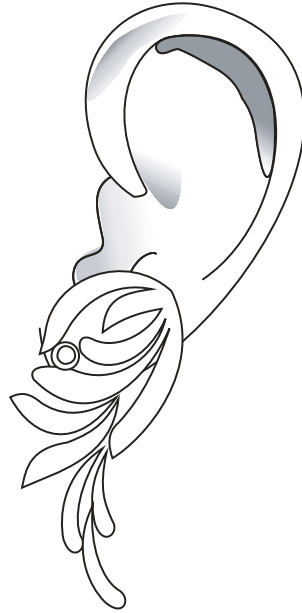

MOVIMENTOS

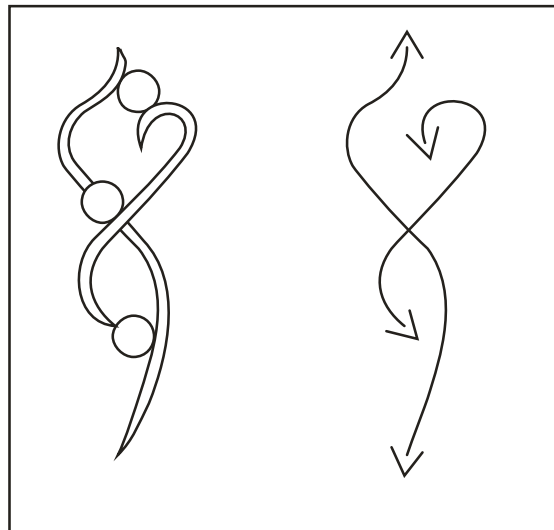
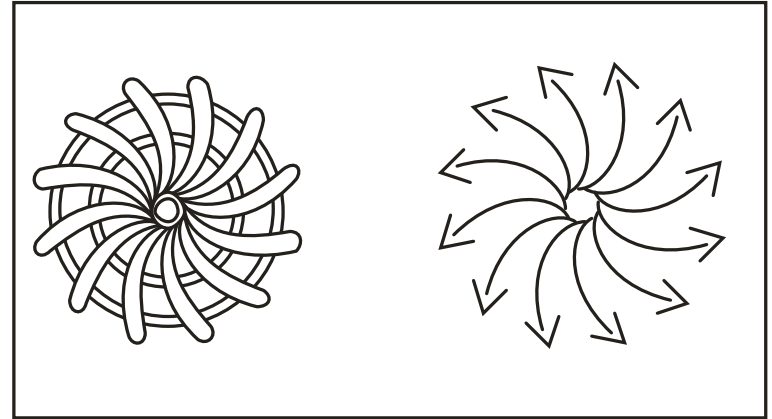
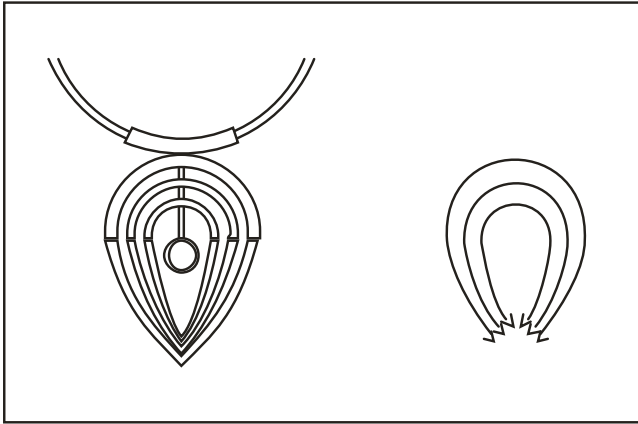



OBJETOS DO COTIDIANO

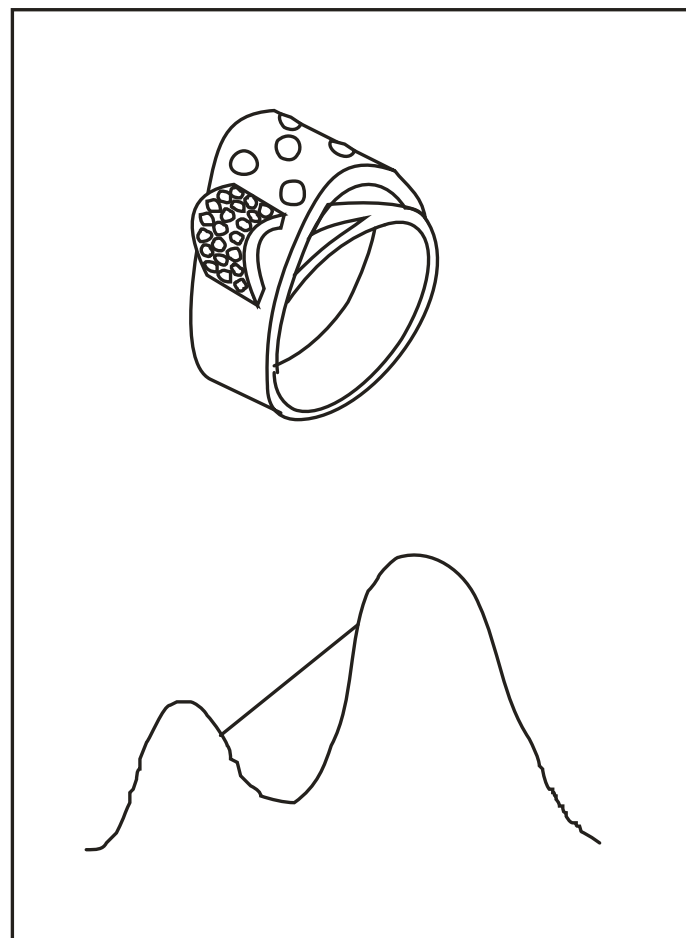
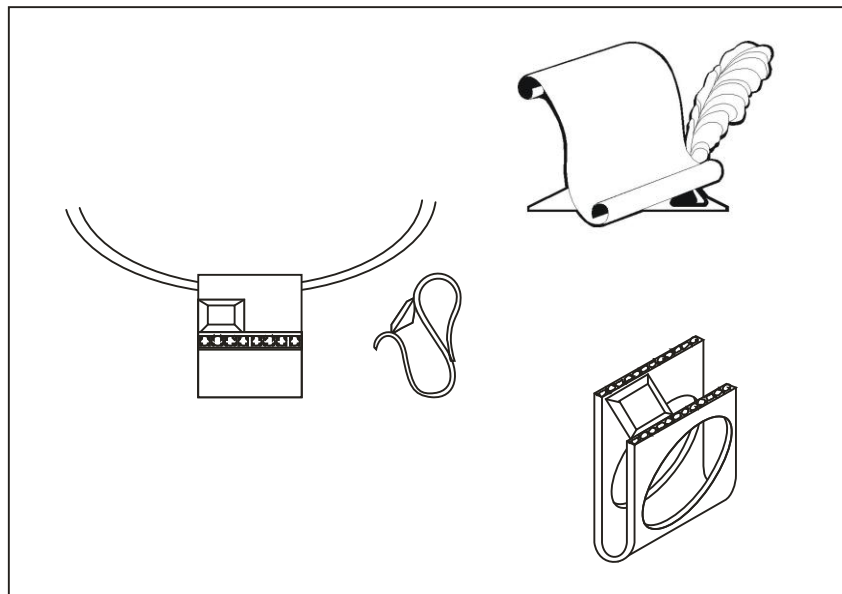



DESENHO TÉCNICO

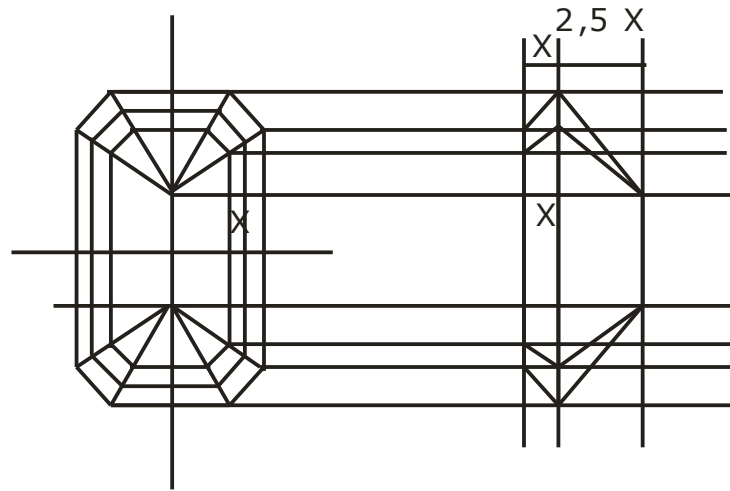
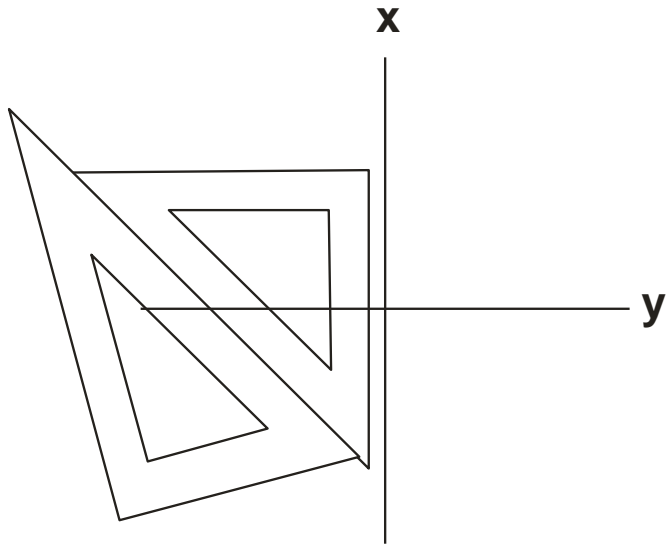

8

DESENHO TÉCNICO

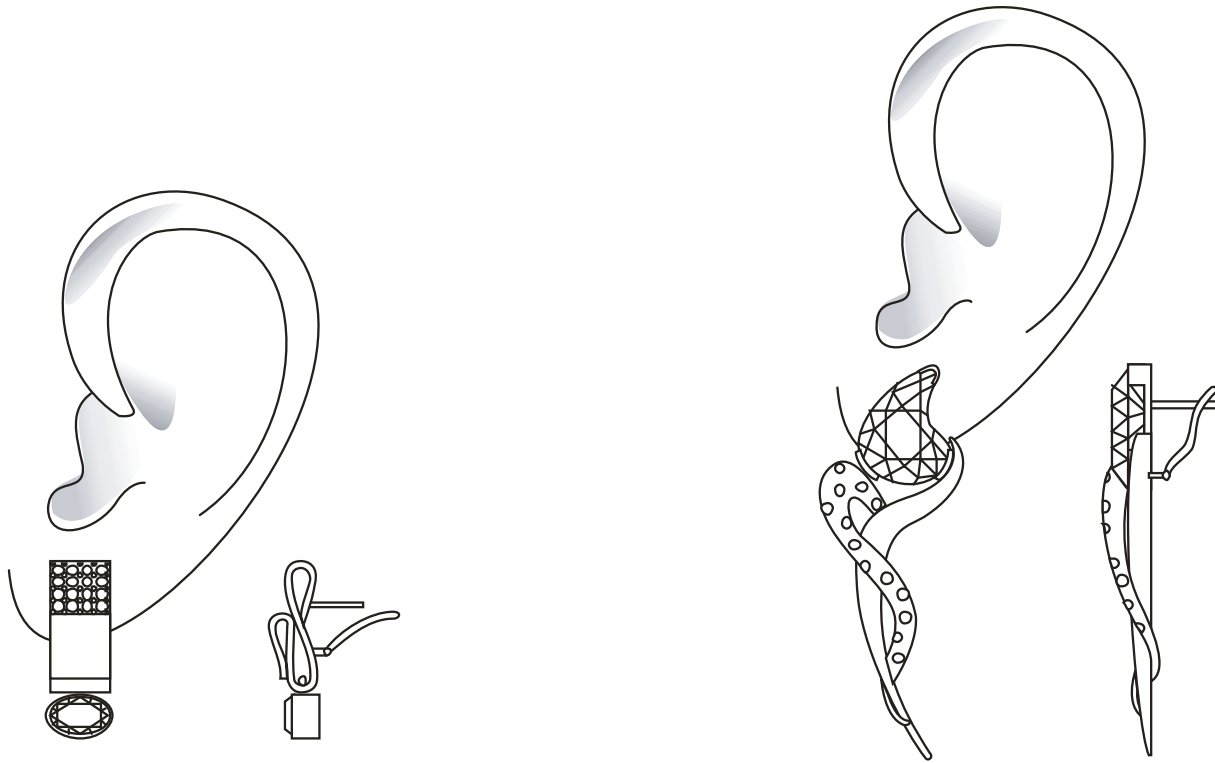

DESENHO TÉCNICO

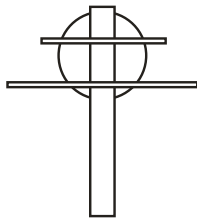
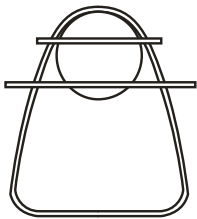
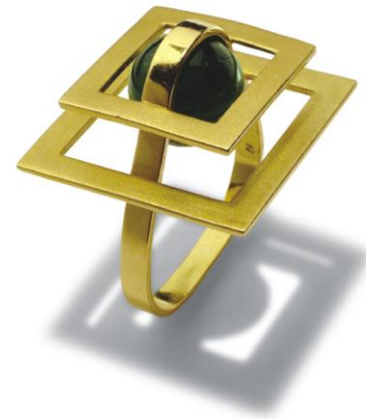
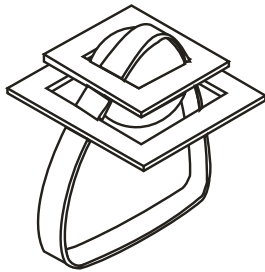
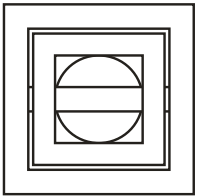

PERSPECTIVA DE ALIANÇAS

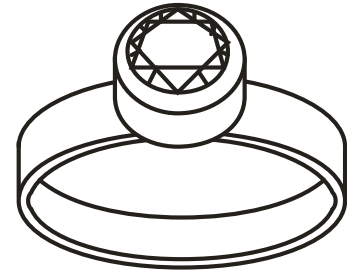
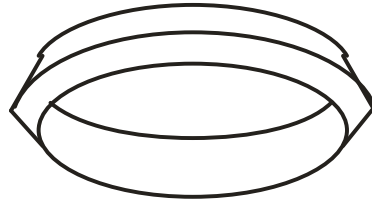
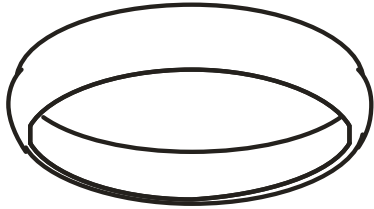

PERSPECTIVA DE ANÉIS

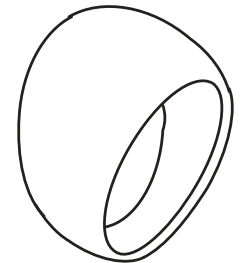
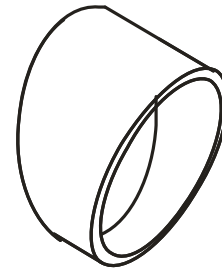
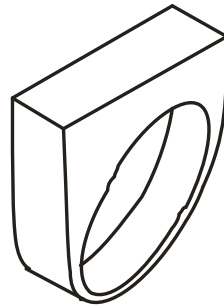
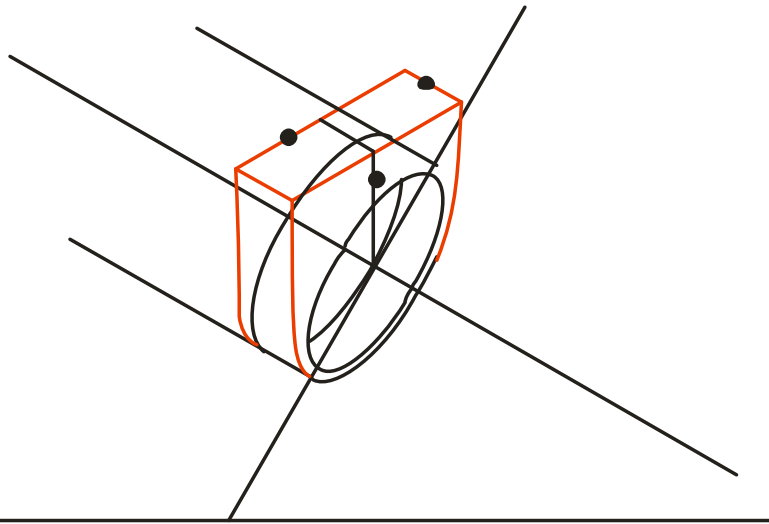

PULSEIRAS ESCRAVAS E MALEÁVEIS

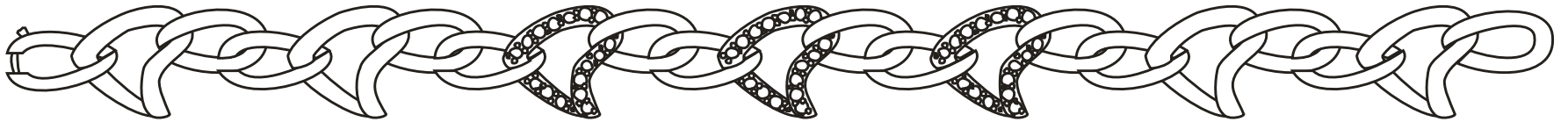
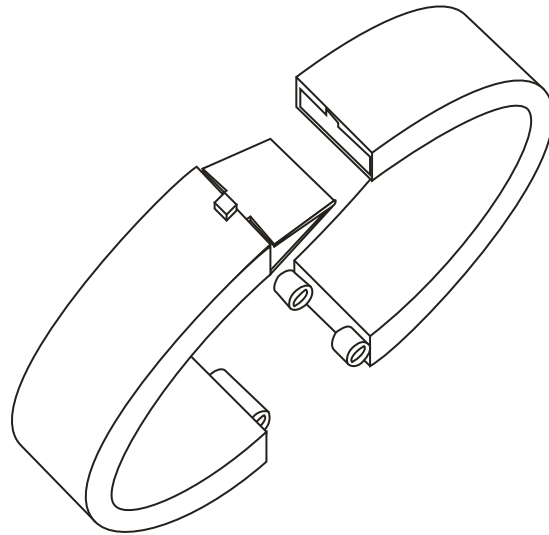

COLARES MALEÁVEIS



COLARES RÍGIDOS

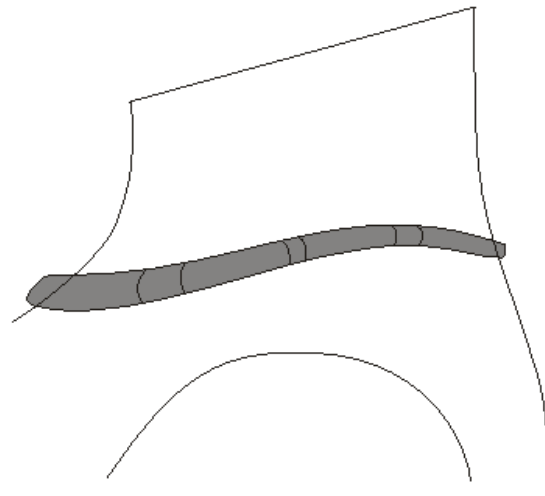
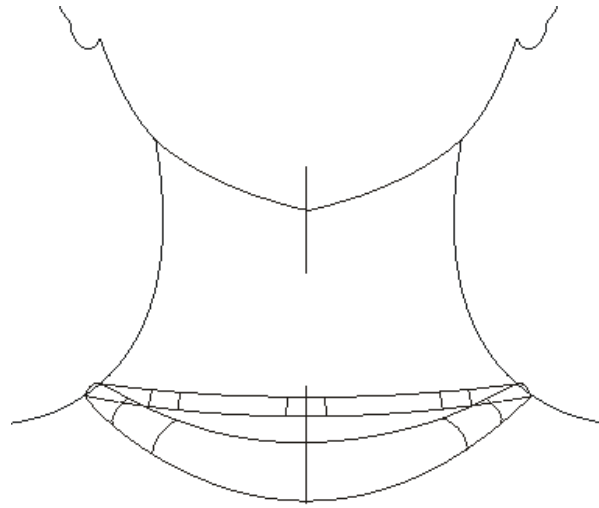

COR

